

SIP CLIENT

Application User Manual

Configuring and Using SIP Client Application

Document Name:	Application User Manual
Document ID:	20160721ASI1
Document Date:	21. Jul. 2016
Document Version:	1.24
Product Name / Version	SIP Client / V02.16

DOCUMENT REVISION TABLE

Date	Version	Who	Change
02/02/10	Draft	AD	First draft
12/03/10	1.0	ASI	Adapted for SIP v0.24: - changed the format of the returned info from Q command; - fixed some typos; - formatted tables to repeat heading when split
13/07/10	1.1	ASI	Adapted for SIP v0.26: - added "Enable relay on call answer" feature description; - fixed some typos - updated some screen-shots from the web UI
15/02/11	1.2	ASI	Reworked for SIP v1.00: - changed the pictures and help items for the webUI; - added Annunicom 155 and PS16 specific information;
08/03/11	1.3	ASI	Added Quick Setup Guide and reworked the SIP profiles configuration information
31/03/11	1.4	ASI	Adapted for SIP v1.08: - added information about notification messaging
20/05/11	1.5	ASI	Adapted for SIP v1.09: - added notes for using the serial command interface
12/07/11	1.6	ASI	Adapted for SIP v1.12: - changed document and SIP client versions; - fixed broken cross references and some typos.
14/09/11	1.7	ASI	Adapted for SIP v1.13: - added information about using the serial gateway
10/01/12	1.8	ASI	Adapted for SIP v1.14 - added notes for using the DNS Renewal feature
19/01/12	1.9	ASI	Adapted for SIP v1.15 - added info about the usage of the DS command; - added info about Stream Timeout configuration parameter.
01/03/12	1.10	ASI	Added X8 configuration chapter and comments on using DTMF commands 3 and 4, refreshed TOC and illustration index
23/03/12	1.11	ASI	Adapted for SIP v2.03 - changed document and SIP client versions - added info about the "Default REGISTER Time" configuration option
10/04/12	1.12	ASI	Adapted for SIP v2.04 - changed document and SIP client versions
04/05/12	1.13	ASI	Adapted for SIP v2.05 - changed document and SIP client versions
08/06/12	1.14	ASI	Adapted for SIP v2.06 - changed document and SIP client versions - added info about the AEC feature
10/10/12	1.15	ASI	Adapted for SIP v2.10 - added document ID table - changed document and SIP client versions - added info about "Enable relay on call ring" - added info about "Beep on call answer" - updates application config status page picture - aligning pages
25/10/12	1.16	ASI	Adapted for SIP v2.11 - changed document and SIP client versions

Date	Version	Who	Change
25/04/13	1.17	ASI	Adapted for SIP v2.12 - changed document and SIP client versions - added about using DTMF and SIP INFO dialling from third party phones - changed formatting and pictures with the new Barix template
17/10/13	1.18	ASI	Adapted for SIP v2.13 - changed document and SIP client versions
13/01/14	1.19	ASI	Fixing minor formatting issues
16/01/14	1.20	ASI	Fixed some spelling mistakes and replace all the occurrences of the old Barix logo with the new one
25/08/15	1.21	ASI	Adapted for SIP v2.14: - relay control and set dial target API commands - information about using Authentication ID, Call Timeout and the updated Auto Hangup timeout behaviour - updated document and SIP client versions
26/08/15	1.22	ASI	Added a paragraph for server compatibility and updated device compatibility list
13/06/16	1.23	ASI	- Added information about the call answer (DA) CGI command - Increased the SIP Client version to 2.15
21/07/16	1.24	ASI	Adapted for SIP v2.16: - added info about the backup SIP server entry - increased the SIP Client version to 2.16 - fixed the formatting of some paragraphs

Table of Contents

1 Introduction.....	7
1.1 About “SIP Client”.....	7
1.2 Features.....	7
1.3 SIP features.....	7
1.4 Supported hardware.....	8
1.5 Additional documents.....	8
1.6 ABCL SIP firmware.....	8
1.7 About this manual.....	8
Links to chapters.....	8
Bookmarks pane in Adobe Acrobat.....	8
Chapter overview.....	8
2 System requirements.....	10
2.1 SIP environment.....	10
2.2 SIP server compatibility.....	11
3 Quick Start Guide.....	12
3.1 Connecting an Annunicom I00 device.....	12
STEP 1.....	12
STEP 2.....	12
STEP 3.....	12
STEP 4.....	12
3.2 Configuring the SIP client.....	13
4 Advanced WEB UI configuration.....	17
4.1 Home page.....	17
4.2 Profiles Page.....	19
4.3 Configuration Page.....	22
NETWORK SETTINGS.....	22
SIP PROTOCOL SETTINGS.....	24
OUTBOUND CALL SETTINGS.....	25
INBOUND CALL SETTINGS.....	26
AUDIO SETTINGS.....	28
STREAMING.....	29
CONTROL INTERFACES.....	30
SECURITY SETTINGS.....	31
4.4 Status Page.....	32
4.5 Factory Defaults Page.....	36
4.6 Update Page.....	37
Updating files.....	37

5 Notes on Asterisk SIP server configuration.....	39
5.1 SIP registration (REGISTER method).....	39
5.2 SIP calls (INVITE method).....	40
6 Extra features in the SIP Client application.....	41
6.1 Inputs, outputs and relays.....	41
6.2 DTMF/SIP INFO commands.....	41
6.3 Control interface.....	42
6.4 Audio rebroadcast.....	44
6.5 Background music.....	44
6.6 Notification Messaging.....	44
6.7 Using SIP Client with PS16	45
Configuring PS16	45
Receiving Incoming Calls.....	45
Making Outbound Calls.....	45
6.8 Using the serial interface	45
Command Mode.....	47
Sending Data Using the X Command	47
Transparent Serial-to-TCP passive gateway.....	50
6.9 Configuring and connecting X8.....	51
X8 pinout.....	51
Programming X8.....	51
Configuring the COM port for X8.....	52
Connecting the X8 to Annunicom 100/200.....	52
Connecting the X8 to Annunicom 155	52
Connecting buttons to the X8 Unit.....	53
6.10 Using the Backup SIP server feature.....	54
7 Common issues.....	55
7.1 SIP server compatibility.....	55
Early SDP Offer vs. Late SDP Offer.....	55
Authentication ID.....	55
SIP Proxies and Virtual IP configurations.....	55
7.2 SIP REGISTER fail.....	55
7.3 Remote peer don't receive any audio after call established.....	55
7.4 Nothing audible after call established.....	55
7.5 Internet dialog, audio missing after call established.....	56
7.6 Internet dialog, call terminate early.....	56
7.7 Background music does not start.....	56
7.8 DTMF command not executed, or the door relay is not opened.....	56
8 Additional Information.....	57
8.1 WEB UI "ABCL SIP" firmware update.....	57
8.2 Updating a device using the RS-232 serial port.....	57

8.3 BIN / DEC / HEX conversion.....	58
9 Dictionary.....	59
10 Legal Information.....	64

1 Introduction

1.1 About “SIP Client”

SIP Client application has been developed to allow Barix devices supporting a standard “telephone fashion” voice over IP communication, using the widely used application-layer control protocol known as “SIP” (Session Initiation Protocol, RFC 3261).

To understand part of this document, a basic knowledge of the SIP protocol features and terminologies is required.

The SIP Client application can be configured to work either in a peer to peer mode or in a proxy based (PBX) connection .

Over the basic features of the SIP call dialogs, additional features has been added, like background music, audio rebroadcasting and special DTMF commands.

1.2 Features

- SIP (RFC 3261) compliant architecture
- Supporting profiles for easy configuration
- Configurable destination number to call for every input contact
- Configurable call “pick up”/”hang off” timeout interval
- Configurable “call/close on level” feature
- Configurable “peer to peer” or “proxy based” connections
- Configurable SIP and audio RTP ports
- Support for G.711 audio
- Audio rebroadcasting
- Priority based notification audio messaging
- DTMF door open key sequence
- Configurable relay to switch on at call answer/call ring
- Configurable beep on call answer
- Serial, UDP, TCP or CGI control interface
- Transparent bidirectional Serial-To-TCP gateway
- Background music (BGM)
- Friendly profile based WEB configuration UI
- 10/100 Mbit Ethernet connection supports automatic network configuration (BOOTP, DHCP, IPzator, and as well as manual static IP configuration)
- Syslog debugging messages
- X8 support, 8 additional inputs for predefined calls

1.3 SIP features

- Peer to peer session, device can connect directly to the final UAS trough INVITE, and act as UAS on incoming calls
- Transaction through a intranet or Internet UAS, device can register to an outbound Registrar, and establish dialogs through an outbound Proxy
- UAC supported methods: REGISTER, INVITE, CANCEL, BYE, ACK

-
- Supported status messages: 200, 180, 603
 - Processed methods and status messages: INVITE, CANCEL, BYE, INFO (for DTMF), ACK
 - Processed status messages: 200, 180, 401, 403, 407, 503, 603

1.4 Supported hardware

The SIP Client solution is designed to run on the following Barix devices:

- Annunicom 60/100/155/200/1000
- Annunicom PS1
- Annunicom PS16
- IPAM 100, IPAM 102 and IPAM Carrier Board
- IPAM 300 and IPAM 302
- Exstreamer 100/105/110/120/200/205/P5, used as receiver only
- Instreamer used as encoder only

1.5 Additional documents

Technical specifications for the supported devices can be found in the corresponding product sheet which can be downloaded from Barix site www.barix.com.

The SIP Client Application has been developed in BCL and is distributed with its source code enabling users to further customise it. For detailed technical information about the programming language please download the “Barix Control Language (BCL) Programmers Manual” from Barix website.

1.6 ABCL SIP firmware

Barix provides the SIP Client application as included in a pre-built ABCL SIP (abcl_sip_vXX.XX_DATE) package. The SIP Client application is guaranteed to work only when it is run with his original ABCL package. Using SIP Client application with a different version of the ABCL package may not work correctly.

1.7 About this manual

Links to chapters

References to chapters (e.g. [X Chapter name](#)) are red and underlined and serve as direct links when viewed in Adobe Acrobat Viewer. Click on the link to jump to the referenced chapter, click on the left arrow icon to jump back to where you came from.

Bookmarks pane in Adobe Acrobat

The complete “Table of Contents” is available in Adobe Acrobat Viewer. Click on the “Bookmarks” pane tab on the left side of Adobe Acrobat Viewer to open it. Click on any bookmark to directly jump to the corresponding part of the manual.

Chapter overview

This manual is divided into the following chapters:

- [Chapter System requirements](#) describing some basic SIP environment and system configurations.
- [Chapter Quick Start Guide](#) explaining how to quickly set up the device for use with the SIP client.
- [Chapter Advanced WEB UI configuration](#) giving a detailed guide for the WEB UI SIP Client configuration.
- [Chapter Extra features in the SIP Client application](#) describing in details how to use some of the advanced features provided by the application.

-
- [Chapter Common issues](#) explaining how to solve the most common issues to have the application working.
 - [Chapter Additional Information](#) explain how to update a firmware package through the WEB UI, how to setup the device network interface, explaining how to rescue a device via the serial port, and illustrate a BIN/DEC/HEX conversion table.
 - [Chapter Dictionary](#) giving a short explanation of some of the most important terms used in this manual.

2 System requirements

2.1 SIP environment

The SIP Client application can run through a 10/100 Mbit Network, as a peer to peer application, or as a standard SIP “user agent client/server” (UAC/UAS) in a PBX environment.

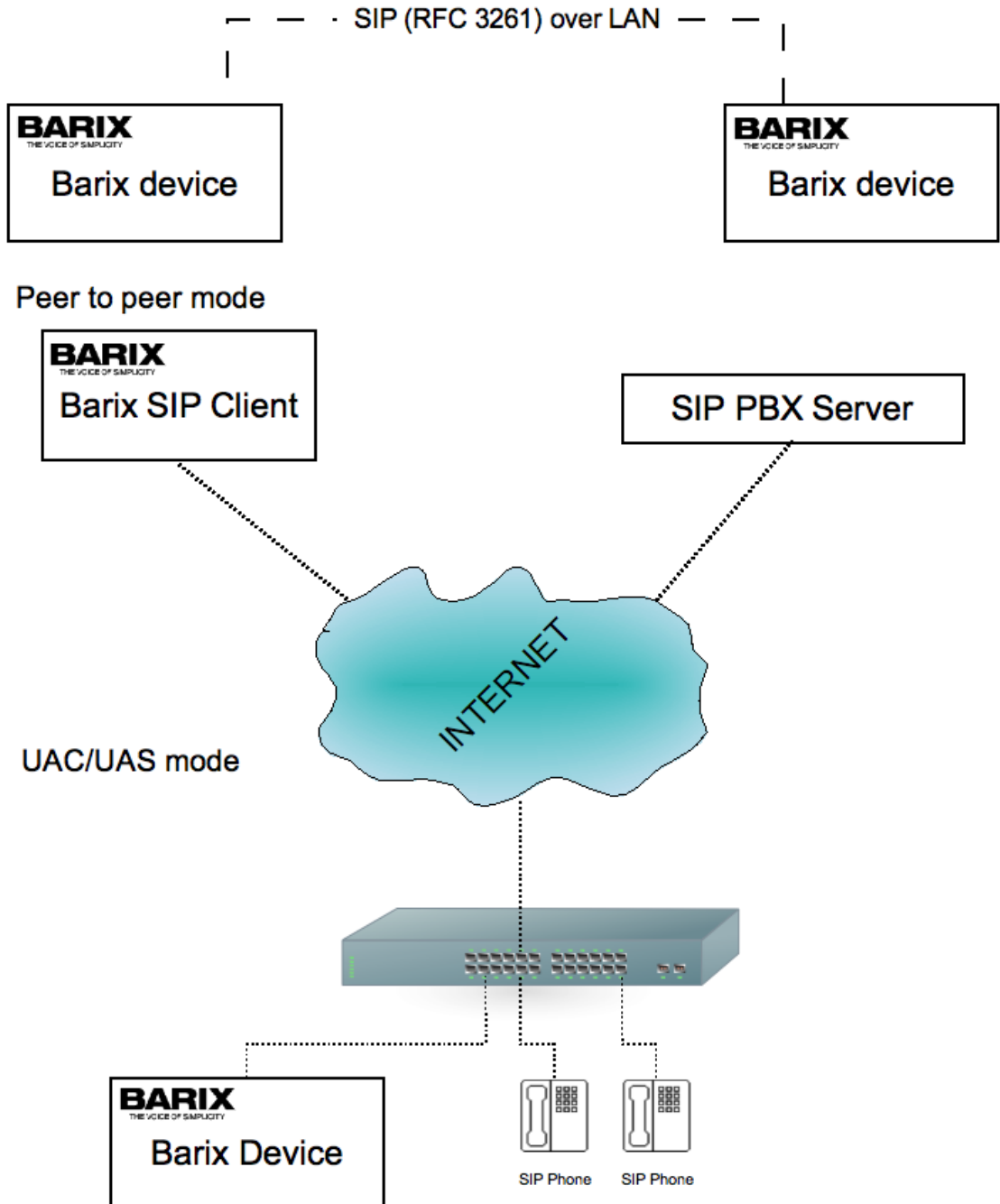

Illustration 1: SIP Client use cases

2.2 SIP server compatibility

The SIP Client application has been tested with the following list of SIP Registrar Server/PBX:

- Asterisk 1.4.29
- OpenSER 1.3.2-notls (i386/linux)
- FreeSWITCH 1.0.head (git-00207ce 2010-09-30 02-37-57 -0400)

The following SIP servers have been confirmed to work by our partners with some limitations (see chapter SIP server compatibility for more details):

- Cisco UCM 8.x/9.1
- Panasonic NCP
- Mitel
- 3CX
- 3Com/HP VCX 7210 IP Call processor
- Shoretel

Interoperability with other SIP servers is not guaranteed.

3 Quick Start Guide

This chapter explains how to do the initial setup of the SIP client assuming that you have already pre-loaded it on the device. If this is not the case, then please refer to chapters WEB UI ABCL SIP firmware update and “Updating advice using the RS-232 serial port“ for more information about loading the SW on the device and revert to factory defaults.

3.1 Connecting an Annunicom 100 device

As an example we will show here how to use the BARIX SIP Client FW running on Annunicom 100 device. Other Barix HW can be configured in a similar way. For more details on connecting Annunicom 155 refer to the Annunicom 155 Product Manual on [Barix Download page](#).

STEP 1

Plug a standard (straight) network cable into the LAN port of the Annunicom and the other end into your switch connected to your LAN.

STEP 2

Annunicom 100 is designed to work with electret microphones by providing 2.7V (max 300 μ A) bias power. Connect your electret microphone as shown on Illustration 2: Connecting Annunicom 100.

In most of the cases, for 2 pin microphones you need to shorten the Mic and + pins as the internal circuitry of Ann 100 provides the separating capacitor of 390 nF.

If your mic has 3 pins (output, bias/power, ground) then connect them to pins Mic, +, and ground accordingly. For more information about the specific microphone you might be using, please refer to its technical specification and proposed wiring diagram.

STEP 3

Connect your speaker to pins 5 and 6 of the upper connector. The Annunicom 100 built-in amplifier is able to drive 2W on 4 Ω speakers. If more power is needed, then use the Line Out on the front panel to connect the Annunicom 100 to your external audio amplifier.

STEP 4

Last, you need to connect one button to be able to call a predefined number and answer/close incoming calls. Connect your button on pins 1 and 3 of the lower connector thus shortening input 0 (INO) to ground to activate the digital input.

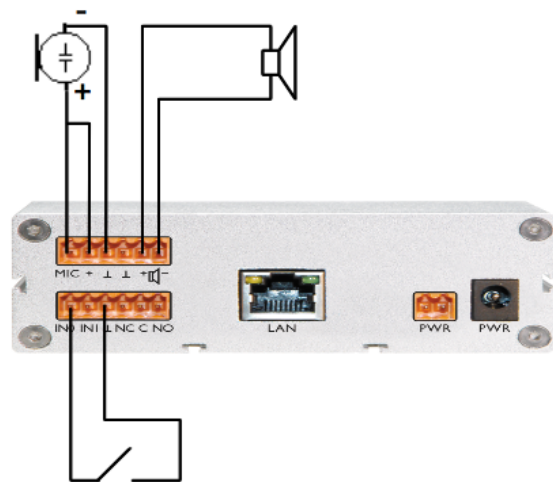

Annunicom 100 rear connector pinout		
Pin	Upper conn	Lower conn
1	Mic input	Input 0
2	Mic Power (bias)	Input 1
3	Ground	Ground
4	Ground	Relay Closed (NC)
5	Speaker +	Relay common
6	Speaker -	Relay open (NO)

Illustration 2: Connecting Annunicom 100

With this step, your Annunicom 100 is ready to be configured for SIP communication.

3.2 Configuring the SIP client

Once the Annunicom 100 is connected, then power up the device. The device will try to get automatically IP address using DHCP, and announce it on the speaker. If you have no DHCP server, the device may get a default IP address (for example 192.168.1.168). In this case please refer to the NETWORK SETTINGS section from chapter 4.3 for more information how to configure the device with a static IP. After boot, open the device web page with your favourite browser. You will see the empty home page of the SIP client:

HOME PROFILES CONFIGURATION STATUS DEFAULTS UPDATE REBOOT Annunlicom 100 MAC: 00:08:E1:02:8B:FE FW VB1.11

SIP CLIENT

SIP Phone

APPLICATION STATUS

Application Mode SIP Mode

SIP PBX

SIP ID

Time till next Registration **0 seconds**

Call State Idle

Remote Party

AUDIO STATUS

Current Set Volume 0 %

Left Output Peak Level 0 dBFS

Right Output Peak Level 0 dBFS

Left Input Peak Level 0 dBFS

Right Input Peak Level 0 dBFS

DEVICE & X8 I/O STATUS

I/O Contacts

	7	6	5	4	3	2	1	0
Inputs	<input checked="" type="checkbox"/>	<input checked="" type="checkbox"/>	<input checked="" type="checkbox"/>	<input checked="" type="checkbox"/>	<input checked="" type="checkbox"/>	<input checked="" type="checkbox"/>	<input type="checkbox"/>	<input type="checkbox"/>
Relays	<input checked="" type="checkbox"/>	<input checked="" type="checkbox"/>	<input checked="" type="checkbox"/>	<input checked="" type="checkbox"/>	<input checked="" type="checkbox"/>	<input checked="" type="checkbox"/>	<input checked="" type="checkbox"/>	<input type="checkbox"/>

X8 status: X8 not detected

Help

Home page
Gives an overview of the most important settings of the unit.

APPLICATION STATUS

Application Mode
Shows the current mode of the application, and may take the following values:

- *Device is still booting ...*
The Boot process has not finished yet.
- *SIP mode*
The device is in SIP mode. The SIP server name, and the SIP ID are also shown in this case
- *Peer to peer mode*
The device is in P2P mode, and configured to call to only one remote peer. Incoming calls will be accepted only from this peer.

Time till next Registration
Shows the remaining time till the next registration attempt. The current registration status is shown with different colours of the text:

- Device not registered
- Registration in progress
- Device registered

Illustration 3: Home page of unconfigured SIP client

There is no information shown because the SIP client is not yet configured. The registration status is with red colour showing that the device is not registered.

Next, please click on the “Configuration” tab from the navigation menu. The Basic configuration menu page will show up.

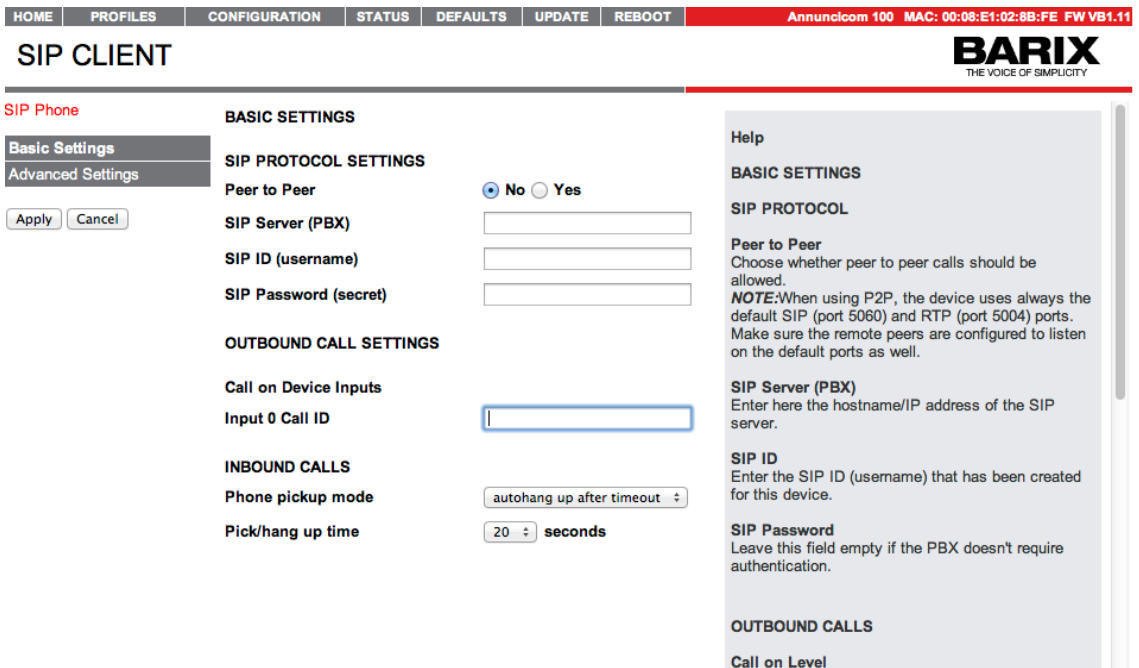

Illustration 4: SIP client Basic Settings menu page

Here you will find the most essential settings that need to be configured for the SIP client to be successfully started. Please contact your network administrator to provide you with the login data for your SIP account, and type them in the corresponding fields.

Setting Name	Purpose	Example value
Server Name (PBX)	The server name or the IP address of your SIP server. The IP be a public (WAN), or private (LAN) IP address. This can be either Asterisk or FreeSWITCH box. In the example a local FreeSWITCH SIP server is used	192.168.11.203 or empty in Peer-to-peer mode
SIP ID (username)	The username used to register on the SIP server	9245
SIP password (secret)	The password for your SIP account	1234 (not displayed while typing)
Input 0 Call ID	The extension ID to be called at button 0 press	9246 or 9246@192.168.11.223 if in Peer-to-peer mode

Leave the other fields (**Peer to peer, Phone pick up mode, and Pick/Hang up time**) unchanged, click the “Apply” button, and wait the device to reboot. If the SIP account settings are correct, the device should register, and its status displayed in green colour on the home page.

Illustration 5: Home page of a configured and registered SIP client

Now the SIP client is ready to make and receive calls. Press button 1 to call to ID 9246¹. The SIP client will start ringing, and a call status “**Calling out**” with “**Remote party: 1002**” will be displayed on the SIP client home page. When the call is answered, a “**In active call**” status shall be displayed.

¹ Make sure that ID 9246 is existing and registered to the same SIP server. This could be another BARIX SIP client, or any HW or SW SIP phone.

4 Advanced WEB UI configuration

4.1 Home page

After power up, the Barix device WEB page is reachable at its IP address. Open your preferred Internet browser, and connect to the device by writing the IP address in the browser URL bar. A menu with a navigation bar and the device home page pre-loaded will show up.

The Home page displays the most essential configuration and status information grouped in the following sections:

APPLICATION STATUS

Application mode

Shows the current mode of the application, and may take the following values:

- Device is still booting ...

The Boot process has not finished yet;

- SIP mode

The device is in SIP mode. The SIP server name, and the SIP ID are also shown in this case. Direct IP (P2P) calls are ignored;

- Peer to peer mode

The device is in P2P mode, and configured to accept direct IP calls.

Time till next Registration

Shows the remaining time till the next registration attempt. The current registration status is shown with different colours of the text:

Device not registered

Registration in progress

Device Registered

Call Status

Shows the current call state, and may take one of the following values:

- Idle:

No audio stream is received, and the SIP client is accepting calls;

- Getting incoming call:

The SIP client has received an INVITE message and is ringing. The ID of the remote party is also displayed;

- Outgoing call:

The SIP client has initiated an outgoing call, and the remote party ID is displayed as well;

- In active call:

The SIP client is in a call session with the displayed remote party.

DEVICE AND X8 I/O STATUS

Displays the available I/Os of the device, and of X8 (if attached). A message "X8 not connected" appears when X8 is not detected.

Device I/O

Device I/O enumeration, bit "0" correspond to the first device input, for example IN0 for Annunicom 100.

Inputs

This section is displayed differently depending on the device HW type.
If Annunicom 155 is detected, it displays the inputs, indicated with the following states:

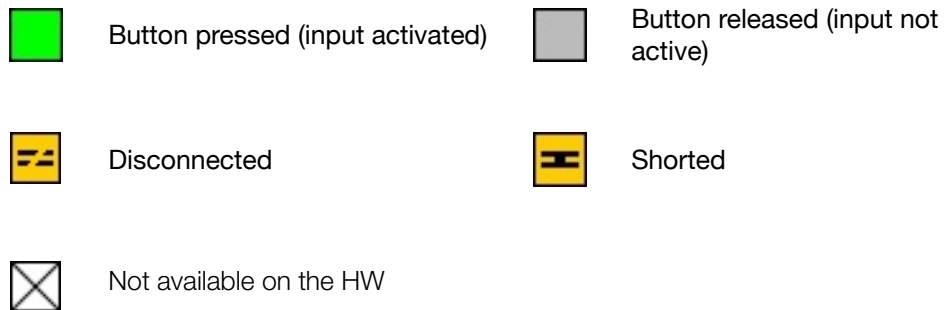

If Annunicom 155 is not detected, the “*Disconnected*” and “*Shorted*” icons are not shown:

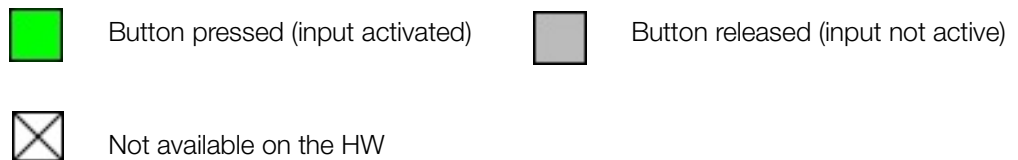

Relays

Monitors the device relays, indicated with the following states:

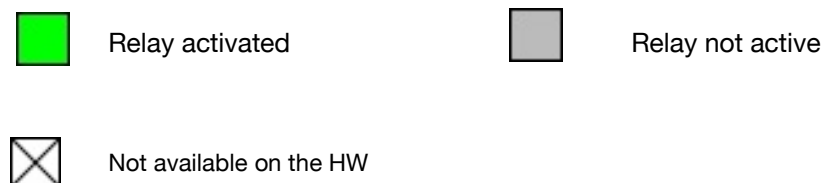

NOTE: please read the ABCL Firmware documentation and the product manual to understand how input, output and relays are mapped, and where they are available.

X8 I/O Status

X8 I/O enumeration, bit 0 correspond to pin 9 of J1 connector. Please refer to X8 manual for additional information.

X8 pin configuration

The pin configuration is indicated with the following icons:

 Set as input  Set as output

For more information how to change the pin configuration please refer to the X8 manual.

X8 input register

X8 input register status. Please refer to X8 manual for additional information.

X8 output register

X8 output register status. Please refer to X8 manual for additional information.

AUDIO STATUS

Shows the status of the following audio parameters:

- Volume:

Displays the current volume in %;

- Left output peak level:

Displays the current left output peak level in dBFS (dB full scale);

- Right output peak level:

Displays the current right output peak level in dBFS (dB full scale);

- Left input peak level:

Displays the current left input peak level in dBFS (dB full scale);

- Right input peak level:

Displays the current right input peak level in dBFS (dB full scale);

4.2 Profiles Page

The Profiles page lets you easily set the application for a given purpose. When a predefined setting is selected, some of the non relevant settings are set to defaults and some are left unchanged, so use this feature with caution. After applying the predefined settings, the SIP client can be additionally customised for the shown properties only.

All profiles have in common access to the complete set of settings from the following sections:

- SIP Protocol Settings
- Door Settings
- Control Interfaces Settings
- Notification Messaging Settings

In addition, each profile provides extra customisation settings.

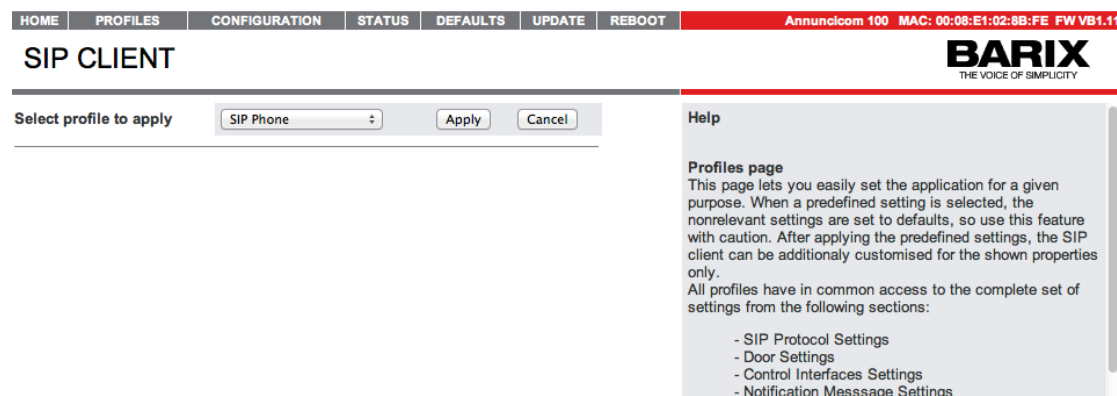

Illustration 6: SIP Client Profiles page

The following profiles are available:

SIP Phone

This is the typical use of the SIP client. In this mode you can:

- Establish a full-duplex phone communication;
- Call up to 16 (with X8 attached) IDs;
- Select the audio input;

The following additional options are enabled in this mode:

- Close on timeout;
- Close on Input 0-7 and X8 Input 0-7;
- Input audio buffer level;
- Input audio source;
- Encoding;
- Volume;
- Mic and AD gains

SIP Paging Station

In this mode the SIP client is used as an end point for getting SIP Paging messages. The typical use scenario in this case is to configure the SIP server to call a group of SIP clients which will auto-reply and play locally the sent audio. While in idle mode, the SIP paging station may play background music.

The following additional options are enabled in this mode:

- Encoding;
- Volume;
- BGM IP Address and Port;

-
- BGM volume and input audio buffer

SIP Paging Gateway

In this mode the SIP client is used to rebroadcast the incoming call to a specific multicast address, and port number. All Outbound Calls related settings are reset to the factory defaults. The following additional options are enabled in this mode:

- Encoding;
- Volume;
- Audio Rebroadcast Address and Port.

SIP Door Station

The device is to be used as a door intercom station. Pushing the button causes the device to ring, and closes the call automatically after some time if not answered. In this mode the SIP client can be used in half duplex mode with AI Phone door panels. The phone pickup mode is preset to “*auto answer*” and cannot be changed.

The following additional options are enabled in this mode:

- Close on timeout;
- Close on Input 0-7 and X8 Input 0-7;
- Input audio buffer level;
- Input audio source;
- Encoding;
- Volume;
- Mic and AD gains;
- Talk mode (HDX or FDX);
- Output trigger level and trigger level timeout for the Voice Activity Detection (VAD);
- AI Phone support (On/Off)

SIP Monitoring Point

In this mode the SIP client is used to call a predefined number if the input audio level exceeds certain level. As here only the Call/Close on level options are used, all IDs to be called on digital input are cleared (reset the factory defaults). The audio source input is preset to “*Mic*” and cannot be changed.

The following additional options are enabled in this mode:

- Call on level (Yes/No);
- Call on level ID;
- Level Threshold;
- Close on Level (No/Time in seconds);
- Close on timeout (No/Time in seconds);

4.3 Configuration Page

The configuration page consists of three frames - the menu navigation section, the settings section, and the help section.

The menu navigation section contains two menus - Basic and Advanced. While the Basic menu shows only the most essential settings needed to initially configure the application, the Advanced menu gives access to all settings available for the selected application profile.

Clicking on the selected menu options shows the configuration options, and their relevant help page. After configuring the needed options, click the "Apply" button to save the changes.

NOTE: Settings are not preserved if you switch between the *Basic* and *Advanced* menus. Make sure you apply the changes you have already done before switching to the other menu!

The screenshot shows the SIP Client configuration interface. At the top, there is a navigation bar with tabs: HOME, PROFILES, CONFIGURATION (selected), STATUS, DEFAULTS, UPDATE, and REBOOT. To the right of the tabs, it displays 'Annunicom 100 MAC: 00:08:E1:02:8B:FE FW VB1.11'. Below the navigation bar, the title 'SIP CLIENT' is centered, and the 'BARIX THE VOICE OF SIMPLICITY' logo is on the right. The main content area is divided into three sections: 'SIP Phone' (with 'Basic Settings' selected), 'SIP PROTOCOL SETTINGS', and 'OUTBOUND CALL SETTINGS'. The 'SIP PROTOCOL SETTINGS' section includes 'Peer to Peer' (radio buttons for No and Yes), 'SIP Server (PBX)' (text input: sipstest.barix.com), 'SIP ID (username)' (text input: 9244), and 'SIP Password (secret)' (password input field). The 'OUTBOUND CALL SETTINGS' section includes 'Call on Device Inputs', 'Input 0 Call ID' (text input: 9223), 'INBOUND CALLS', 'Phone pickup mode' (dropdown menu: autohang up after timeout), and 'Pick/hang up time' (text input: 20 seconds). A 'Help' section on the right provides detailed instructions for each setting.

Illustration 7: SIP Client Configuration page

Below is the full list of configuration options available in the Advanced menu. Please be aware that not all of them may be visible depending on your selected profile.

NETWORK SETTINGS

Use SonicIP

If set to "yes", the device will announce its IP address over the audio output during device startup.

Default: "yes"

IP Address

Enter the 4 values of the desired device IP address e.g.:

"0.0.0.0" for automatic discovery (DHCP/BOOTP, IPzator, AutoIP)

"192.168.0.12" for an internal LAN

Default: "0.0.0.0"

Netmask

Enter the 4 values of the desired Static IP e.g.:
"0.0.0.0" for a default Netmask depending on the used IP Address.
"255.255.255.0" for a C class network
Default: "255.255.255.0"

Gateway IP Address

Enter the 4 values of the desired Gateway IP address e.g.:
"0.0.0.0" for no Gateway
"192.168.0.1" for a Gateway in a LAN
Note: The Gateway has to be set only when connecting to other devices over the WAN (through a router).
Default: "0.0.0.0"

Primary DNS

In this field you can give the desired primary and alternative DNS IP address to be able to connect to URLs (e.g. www.radio.com).
Example: "195.186.1.111"
Default: "0.0.0.0"

Alternative DNS

In this field you can give the desired alternative DNS IP address in case the primary DNS is not reachable.
Example: "195.186.4.111"
Default: "0.0.0.0"

Syslog Address

Destination address for syslog messages sent by the BCL program via the SYSLOG command. Set this to your syslog logging machine, if your syslog messages are recorded centrally. If set to 0.0.0.0, syslog messages are broadcast.
Default: "0.0.0.0"

DHCP Host Name

Name of the device sent in DHCP request. If left empty, a name based on the device's MAC address is generated automatically. Enter up to 15 Characters.

Web Server Port

Defines the port where the web server of the device can be reached. If set to "0" the default HTTP port (80) is used.

SNMP System Name

SNMP MIB entry for system name (system.sysName.0)

SNMP System Location

SNMP MIB entry for system location (system.sysLocation.0)

SNMP System Contact

SNMP MIB entry for system contact (system.sysContact.0)

This parameter can be queried using any SNMP browser but can not be updated.

SIP PROTOCOL SETTINGS

Peer to Peer

Choose whether peer to peer calls should be allowed.

NOTE:When using P2P, the device uses always the default SIP (port 5060) and RTP (port 5004) ports. Make sure the remote peer is configured to listen on the default ports as well.

SIP Server (PBX) / Remote Peer

Enter either the hostname/IP address of a SIP server, or of the remote peer.

Backup SIP Server (PBX)

Enter either the hostname/IP address of of the backup SIP server if you have one. In case when the main server is not available, the device will try to register to the second one.

NOTE: The backup server shall be configured to require the same credentials as on the first one.

SIP ID

Enter the SIP ID (username) that has been created for this device.

SIP Password

Leave this field empty if the PBX doesn't require authentication.

SIP Display ID

Enter the description that you like to have displayed on the remote peer when ringing.

Authentication ID

Enter the Authentication ID given by your SIP provider to use for authentication (if it is different than the SIP ID). Most often you do not need to fill in anything, just leave it empty to use the SIP ID for authentication.

Listen SIP Port

Listening port for the SIP protocol messages. A value of 0 means a default value of 5060.

Listen RTP Port

Listening port for the RTP audio blocks. A value of 0 means a default value of 5004.

Default REGISTER Time

The value that the SIP client suggests to the SIP server when sending the REGISTER request. If this value is accepted by the SIP server, the SIP client has to register after this amount of

time. Allowed values in the range of 60-3600 seconds.

NOTE: The SIP server may overwrite this value in its reply to the REGISTER request.

Send NAT-Keepalives

Enable this function if the device resides behind a NAT.

Periodically Renew DNS

If enabled, it will force the SIP client to renew the DNS of the SIP server every time the registration to the server fails. Use this feature if you have a backup SIP server with the same DNS name and you wish to enable the SIP client to switch to it if the main server fails.

NOTE: This option is mutually exclusive with the "Backup SIP Server (PBX)" setting. When this option is enabled, it will prevent the SIP client from switching to the backup SIP server, and it will stay to the one that has been selected at boot time. In this case the SIP client will keep on resolving the same SIP server name.

Registration Fail Timeout

The SIP client will automatically resolve the DNS of the SIP server if the REGISTER request fails. However, if the SIP server is down, or the REGISTER message gets lost, the SIP client will not get reply from the server. So configure here the timeout after sending a REGISTER request on the expiry of which the registration will be considered as "failed" in case of no reply from the SIP server.

NOTE 1: Use this feature with caution. Setting this value too low may result in registration malfunctioning. If unsure, leave it to the default value.

NOTE 2: This timeout is shared with the "Backup SIP server (PBX)" setting.

Default: 10 seconds

Call Timeout

Enter here in minutes (1-255) the maximum time duration of the call. After the expiry of this timeout the call will be unconditionally closed.

Default: 0 (disabled)

Debug Mode

Sends received or sent SIP messages through Syslog.

OUTBOUND CALL SETTINGS

Auto Hangup Time

If enabled, the device will automatically hang-up after the configured amount of time if no one answers the call. This option is suitable for door station panels that have only one ring button, and no button to cancel the initiated call.

Values: 5 to 90 seconds.

Default: 0 (disabled)

NOTE: When the Auto Hangup Time is disabled, a second press on the Input0/1 button will cancel the started call setup. Please do not disable it if the device is intended to be used as doorstation. If the call is not cancelled with a second button press, the SIP client will anyway

unconditionally drop the call after 120 seconds.enabled, the device will automatically hang-up after the configured amount of time if no one answers the call. This option is suitable for door station panels that have only one ring button, and no button to cancel the initiated call.

Call on Level

If enabled, call can be initiated by audio level. If set to "Yes", then Call on Level ID, Level Threshold and Close Call on Level options are also visible.

NOTE: Call on level is unsupported with "Background Music" enabled.

Call on Device Inputs

Extensions to be called when the correspondent input is closed. The available number of inputs depends from the Barix hardware model.

In "Peer to Peer" mode this field is used to assign the IP of the remote peer to be called. It can contain just remote peer ID, or the IP preceded with its callID.

For example 9999@192.168.0.1 or just 192.168.0.1

Call on Level ID

SIP extension of the device that will be called on audio level detection.

Level Threshold

Minimal audio level to initiate a call. If the input audio level reaches at least the configured threshold, a call will be initiated. The same threshold level is used to terminate the call if the Close Call on Level option is enabled

Values: 0 to 32767.

Default: 1000

Close Call on Level

When enabled, and the input peak level is below the level threshold for the configured amount of time, the call is terminated.

Values: 5 to 30 seconds.

Default: 0 (disabled)

Beep On Call Answer

If enabled, the SIP client will play a short beep sound when the remote party answers the call.

Default: Off

Call on Device Inputs

Extensions to be called when the correspondent input is closed. The available number of inputs depends from the Barix hardware model.

Call on X8 Inputs

Fields allow to assign a SIP extension to be called when an input contact closes, for every available X8 input.

NOTE: these fields are visible and can be set only if the X8 hardware extension is detected.

INBOUND CALL SETTINGS

Input Buffer Level

Maximum delay of the input audio buffer in milliseconds. Decrease this value to minimise delay, increase this value to prevent audio dropouts.
Default setting is "300" ms.

Phone Pickup Mode

Choose how calls should be answered:

autoanswer: the call is auto-answered;

auto-pick-up after timeout: in this mode the bell button is used to answer and terminate a call. If the call is not answered inside "Pick/Hang up After" time period, the device will answer;

auto-hang-up after timeout: (default) in this mode the bell button is used to answer and terminate the call. If the call is not answered inside "Pick/hang up after" time period, the device will decline the call;

not callable: in this mode incoming calls will be declined.

Pick/Hang up After

Set pick/hang up delay if no answer. Only active if the phone pick-up mode is set to manual.

Stream Timeout

In some scenarios the remote party may go offline without explicitly closing the active call. In this case the SIP client may stay in active call state for unlimited amount of time. Set here the time in minutes after which the SIP client will close the active call if there is no audio stream received. You can change between 0 and 600 minutes.

NOTE: Please have in mind that this setting is ignored and reset to "disabled" if you select SIP Monitoring Point profile. Default setting is "0 min (disabled)".

Beep On Call Answer

If enabled, the SIP client will play a short beep sound when the incoming call is answered.
Default: Off

Door Open Code

Set the secret code to open the door by entering this DTMF sequence while communicating with the device. When the sequence is detected from the remote peer, the first relay contact is closed. Leave it empty to disable this functionality.

Open Door Relay for

Set the contact closure duration. After this period, the relay contact is switched back to open.

Enable Relay

Select here when you would like to have the relay enabled. You can choose between "on call answer" and "on call ring"
Default setting is "on call answer" terminated.

Relay Number to Enable

Select here the relay number that you would like to have automatically switched on depending on the "Enable Relay" setting. The number of the available relays varies for the different Barix devices. If invalid relay number is selected, it will be ignored.
Default setting is "disabled"

NOTE: The status of the relay can still be modified with a DTMF command.

AUDIO SETTINGS

Input Source

Select the desired input source.
Default: "Mic".

Encoding

Choose between "uLaw", "aLaw" or "G.722"
Default: "uLaw".

NOTE: G.722 option is displayed only if supported by the HW (devices with IPAM 102)

Volume

Choose between "0%" and "100%" in 5% steps.
Default: "50%".

Microphone Gain

Microphone gain dB, increase if your microphone is too faint, decrease if it's too loud or over-driven.
Default: "21dB"

A/D Amplifier Gain

A/D converter pre-amplification in dB. Increase if the audio signal too faint, decrease if it's too loud or over-driven.
Default: "0dB"

Talk Mode

Choose between full-duplex" and half-duplex talk mode. This option is available only in SIP Door Station profile. When selected, the user has also the possibility to enable the support for AI Phone door panels. Default: "FDX" at factory defaults, and "HDX" when the SIP Door Station Profile is applied.

Output Trigger Level

Defines the audio level from the incoming audio RTP stream which will trigger the SIP client in "listen" mode. This setting is ignored if the door station is configured in FDX mode.
Values: 0 to 32767.
Default: "1000"

Trigger Level Timeout

Defines the timeout in milliseconds, after which if no audio is detected from the incoming RTP stream, the SIP Client should switch back to "talk" mode. This setting is ignored if the door station is configured in FDX mode.

Default: "200 ms"

AI Phone Support

Enable or disable the support for AI Phone door panels. This option is available only in SIP Door Station mode and is automatically set to "No" if FDX talk mode or other profile is selected.

Default: "No"

Acoustic Echo Cancellation

Enable or disable the AEC here.

Note: The AEC option is visible only if supported by the HW (IPAM 102 based devices).

Default: "Off"

STREAMING

AUDIO REBROADCAST

Rebroadcast IP Address

Set the audio rebroadcast IP address.

Rebroadcast Port

Set the audio rebroadcasting port. A value of 0 disable the audio rebroadcasting feature.

NOTE: Rebroadcast will start only if rebroadcast IP:PORT fields are set, using the DTMF start/stop commands.

BACKGROUND MUSIC SETTINGS

BGM Address

Set the BGM listening address.

BGM Port

Set the BGM listening port. If this field is not 0, the BGM listening service is enabled. BGM service listen for a RTP-MP3 incoming stream.

BGM Volume

Set the BGM playback volume.

BGM Buffer

Set the BGM playback delay buffer in milliseconds. **NOTE:** Using both rebroadcast and background music playback is not supported!

NOTIFICATION MESSAGE SETTINGS

Notification Audio IP Address

Configure the notification audio listening address here. Multicast is also supported.

Notification Port

Set the notification audio listening port. If this field is not 0, the notification message listening service is enabled.

Note: The notification audio incoming stream must be RTP. For the supported RTP payload types refer to Chapter Notification Messaging.

Notification Volume

Set the notification message playback volume.

Notification Buffer

Set the BGM playback delay buffer in milliseconds.

Use Inbound Calls Relay

If set to Yes, and Relay Number to Enable at Call Answer from the Inbound Calls section is enabled, then the specified relay will be activated while the notification message is active.

Note: This configuration option is not visible if Relay Number to Enable at Call Answer is set to disabled.

CONTROL INTERFACES

UDP Control Port

Set the UDP control port. A value of 0 disables UDP control support.

UDP Control Port

Set the UDP control port. A value of 0 disables UDP control support.

TCP Control Port

Set the TCP control port. A value of 0 disables TCP control support.

Use Serial Port For

These settings adjust the purpose of the serial port. You can use between the following values:

X8 Extension: In this mode the serial port is used to connect the Barix X8 extension.

Serial Control Interface: In this mode the serial port is used to send commands to the SIP client. For more information how to use it please refer to the SIP User Manual.

Serial GW, TCP, passive: When enabled, the SIP client is waiting for a telnet connection on the specified port. Once established, data can be transmitted between COM port 1, and the host that has established the TCP connection.

Default: "X8 Extension"

Serial GW TCP Port

Configure here the TCP port for the passive TCP Serial Gateway. This option is visible only if passive TCP GW is selected.

Default: "0 (disabled)"

Serial Port 1 Settings

These settings adjust the first serial interface properties.

Baud Rate

Select the serial transmission speed ("300" to "230400" Baud).

Default: "9600"

Data Bits

Select "7" or "8" data bits.

Default: "8"

Parity

Select "no", "even" or "odd" parity.

Default: "no"

Stop Bits

Select "1" or "2" stop bits.

Default: "1"

Flow Control

Select the type of flow control:

RTS/CTS signals not used: "none";

RS232: "Software flow control(XON/XOFF)" or "Hardware flow control (RTS/CTS)";

RS485: "RS485 direction control";

Default: "none".

SECURITY SETTINGS

Reset Function

Enable or disable the "Reset" function on the Reset button and on the WEB UI. In order to restart the device press the Reset button once.

Default: "enabled"

Factory Defaults

Enable or disable the "Factory Defaults" function on the Reset button. In order to revert all settings to factory defaults keep the Reset button pressed until the red LED starts blinking (approx. 10 seconds).

Default: "enabled"

Update Function

Enable or disable the WEB Update function of the device. If the Update function is disabled,

the only way to update the firmware is to use the serial rescue.
Default: "enabled"

Set Password

This is visible as long as no password is set.

Enter a password (up to 25 characters) and hit the "Apply" button. After the restart you should close the browser window and open a new browser window. You will be asked to supply user name and password. The user name can be omitted but the password has to be supplied in order to see the web configuration.

Note: After applying the changes for the password, please restart your browser and reload the home page of the device. If you do not do this, the browser may enter into endless loop asking for the password because of the non protected configuration page still stored in its cache.

Old Password / New Password

These fields are visible as long as a password is set.

To allow free access (clearing the password) enter the old password and leave the field "New Password" empty, then hit the "Apply" button.

After the restart you will not be asked for user name and password anymore.

To change the password enter the old password and enter the new password in the field "New Password", then hit the "Apply" button.

After the restart you will be asked for user name and password. The user name can be omitted but the new password has to be supplied in order to see the web configuration.

4.4 Status Page

This page prints all available configuration options, and can be used for diagnostic purpose. It consists of three sections, split with line separators:

Device Information section, showing all information about the device HW:

SIP CLIENT

System status:

Ticks: 5839703 ms
Uptime: 5839 s

Device information:

Hardware type: (ID 25)
IP address: 192.168.11.226
MAC address: 00:08:E1:00:8E:F5

FW version: A0.36 (02/04/2011)
WEB version: 02.00
Bootloader version: 99.22
Setup version: 01.01
Sg version: 08.17 (Feb 4 2011)
Fs version: 02.05 (02/04/2011)

BCL application:

Name: sip
Version: V1.06 (08 Feb 2011)

USB device info:

Device detected: yes
Vendor ID: 0x0000 Product ID: 0x0000
Device class: 0x0 subclass: 0x0
Interface class: 0x0 subclass: 0x0
Maximum power: 0 mA
Device capacity: 0 kB

Filesystem info:

Filesystem attached: yes
Filesystem type: unknown
Serial number: 00000000

Illustration 8: Device status page

Application Status section, showing a snapshot of the SIP application status:

SIP Status

Active Profile	SIP Phone
Call State	Idle
Remote Party	
Registration Status	Registered, next registration in 160 s
Current Set Volume	50 %
Left Output Peak Level	-99 dBFS
Right Output Peak Level	-99 dBFS
Left Input Peak Level	-54 dBFS
Right Input Peak Level	-66 dBFS

Illustration 9: SIP application status page

Application Configuration section, showing all EEPROM configuration parameters for SIP, even the ones not being shown in the current profile configuration menu:

SIP CLIENT

SIP Configuration

NETWORK SETTINGS

Use SonicIP®	No
IP Address	0.0.0.0
Netmask	0.0.0.0
Gateway IP Address	0.0.0.0
Primary DNS	0.0.0.0
Alternative DNS	0.0.0.0
Syslog Address	0.0.0.0
DHCP Host Name	
Web Server Port	0

SIP PROTOCOL SETTINGS

Peer to Peer	Yes
SIP Server (PBX)	
SIP ID (username)	99993
Listen SIP Port	0
Listen RTP Port	0
Default REGISTER Time	1800 seconds
Send NAT-keepalives	No
Periodically Renew DNS	No
Registration Fail Timeout	10 seconds
Debug Mode	Off

OUTBOUND CALL SETTINGS

Call on Level	No
Call on Level ID	
Level Threshold	1000
Close on Level	disabled
Auto Hangup Time	30 seconds
Beep on Call Answer	Off

Call on Device Inputs

Input 0 Call ID	99991
Input 1 Call ID	PAGE:ALL
Input 2 Call ID	
Input 3 Call ID	
Input 4 Call ID	
Input 5 Call ID	
Input 6 Call ID	
Input 7 Call ID	

Call on X8 Inputs

Input 0 Call ID	
Input 1 Call ID	
Input 2 Call ID	
Input 3 Call ID	
Input 4 Call ID	
Input 5 Call ID	
Input 6 Call ID	
Input 7 Call ID	

INBOUND CALLS

Input Buffer Level	300
Phone Pickup Mode	autohang up after timeout
Pick/Hang up Time	20 seconds
Stream Timeout	disabled
Beep on Call Answer	Off

DOOR AND RELAY CONTROL

Door Open Code	
Open Door Relay for	1 seconds
Enable Relay	on call answer
Relay Number to Enable	disabled

AUDIO SETTINGS

Input Source	Mic
Encoding	uLaw / 8 kHz (G.711)
Volume	10 * 5 %
Microphone Gain	21
AVD Amplifier Gain	0
Talk Mode	END

Illustration 10: SIP Client EEPROM settings status page

4.5 Factory Defaults Page

This page helps you to revert to factory default if needed. To do so please click on "**Revert to defaults**" link to restore all factory settings except "Network configuration".

While restarting the device a screen appears showing a number counting down. On device start up a screen appears stating the successful reverting to factory defaults.

If you need to revert also the "Network configuration" settings to factory defaults please press and hold the Reset button for about 10 seconds while the device is powered.

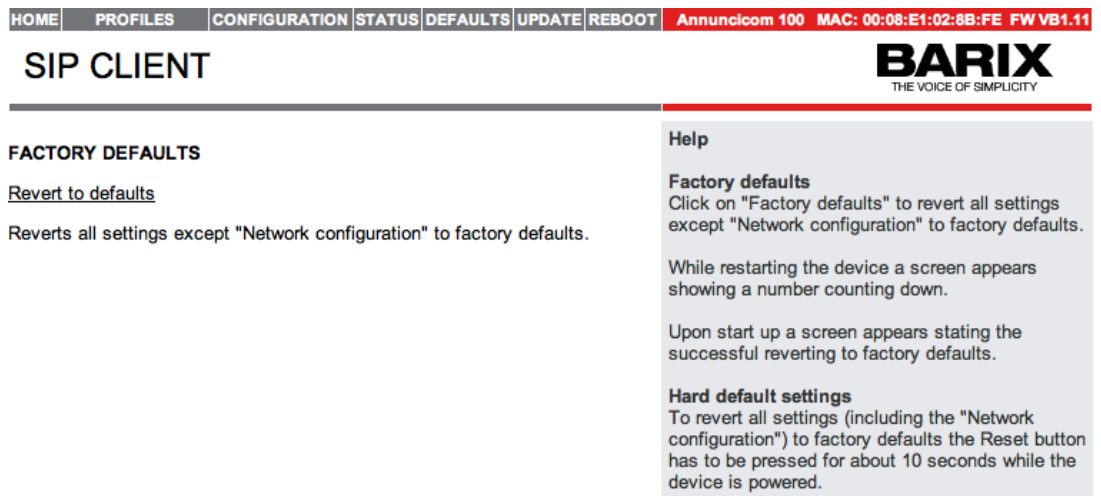
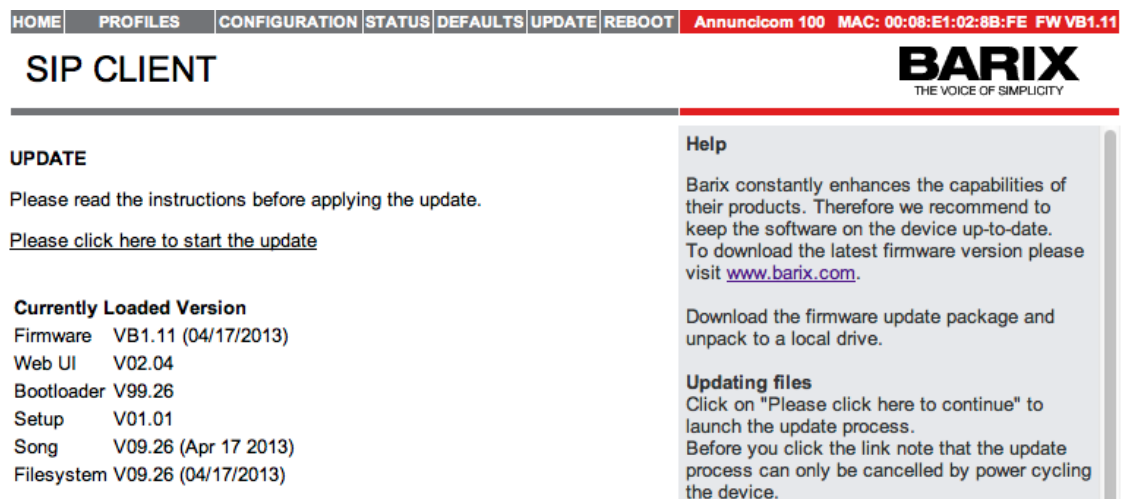

Illustration 11: Factory Defaults page

4.6 Update Page

This page helps you to do a full, or partial FW update of your device. For more details how to do it please refer to WEB UI ABCL SIP Firmware update chapter.



Updating files

Click on "**Please click here to continue**" to launch the update process. Please have in mind that the update process can **ONLY** be cancelled by power cycling the device.

The device will restart in a special mode called "*Bootloader*", and a screen appears showing a number counting down.

Note: In this mode the standard http port 80 is always used.

To upload a resource click on "Browse..." to locate the file you want to update. Once selected, click on "Upload". This upload process can take a few seconds.

After a successful upload the following text appears:

compound.bin successfully loaded.

Click on [update](#) before updating the next component or unplug the power supply to reboot the device.

If you choose "update" you may upload another resource or click the "reboot" button.

If you choose to reboot the following text appears:

rebooting...

Click [here](#) to reload the main page.

The device takes a few seconds to reboot. If you have a fixed IP address or DHCP resolves to the IP address used before, the main page will appear.

5 Notes on Asterisk SIP server configuration

5.1 SIP registration (REGISTER method)

In “peer to peer” mode, a basic SIP dialog can be established just setting up “Remote Peer” and “SIP Id” fields.

To establish a SIP dialog through a SIP PBX/Server, “SIP Server”, “SIP Id” and “SIP Password” must be set, and the registration process must succeed.

A correspondent entry for this account must be created on the server side. Server configuration depend from the brand and model of the SIP PBX, please see the server side documentation for this.

Below is reported a server configuration example for the Asterisk open-source PBX, supposing that both the Barix device and the Asterisk PBX are in the same local network, that both are in the same network subnet (192.168.0.XXX) and that the server network address is 192.168.0.20.

In “sip.conf” configuration file:

```
[ann01]
type=friend
username=ann01
secret=1234
host=dynamic
```

In “extensions.conf” configuration file:

```
exten => 10001,1,Dial(SIP/ann01)
```

After the Asterisk server is configured and restarted, Barix device should successfully register to the PBX using the following settings:

```
SIP Server (PBX)/ Remote Peer : 192.168.0.20
SIP Id : ann01
SIP Password : 1234
Listen SIP Port : 0
Listen RTP Port : 0
Send NAT Keepalives : No
Debug mode : On
```

The “Debug mode” option set to “On” allow to verify if the Barix device has correctly registered to the SIP server. Using a common Syslog application, like for example “Kiwi Syslog Daemon” (www.kiwisyslog.com) or a similar tool, after a successful registration process the following debug messages will be displayed:

```
[OUT] REGISTER
[in ] 100
[in ] 401
[OUT] REGISTER
```

[in] 100

[in] 200

200 (Ok) status message received (in) is showing that SIP Client application has correctly registered to the server, and is ready to issue or receive calls.

5.2 SIP calls (INVITE method)

Note: before performing any call through a PBX server, please be sure the registration process has succeeded, as shown in the section above.

Calls can be issued using the “Call on Level” feature, or closing an input contact, as preconfigured on the WEB interface. Until the remote peer answer or reject the call, a bell ring sound will be audible.

After the call has been answered, full duplex audio communication starts immediately.

Any input contact closure terminate (BYE method) the current call.

6 Extra features in the SIP Client application

6.1 Inputs, outputs and relays

SIP Client support different Barix devices, every hardware type have different Input, Output and Relay capabilities.

The WEB UI shows the device input, output and relay states, and if a Barix X8 is connected, the related input, output and relay states will be shown.

DEVICE & X8 I/O STATUS								
I/O Contacts								
	7	6	5	4	3	2	1	0
Inputs	<input type="checkbox"/>	<input type="checkbox"/>	<input type="checkbox"/>	<input type="checkbox"/>	<input type="checkbox"/>	<input type="checkbox"/>	<input type="checkbox"/>	<input type="checkbox"/>
Relays	<input type="checkbox"/>	<input type="checkbox"/>	<input type="checkbox"/>	<input type="checkbox"/>	<input type="checkbox"/>	<input type="checkbox"/>	<input type="checkbox"/>	<input type="checkbox"/>
X8 I/O								
	7	6	5	4	3	2	1	0
Pin configuration	<input type="checkbox"/>	<input type="checkbox"/>	<input type="checkbox"/>	<input type="checkbox"/>	<input type="checkbox"/>	<input type="checkbox"/>	<input type="checkbox"/>	<input type="checkbox"/>
Input register	<input type="checkbox"/>	<input type="checkbox"/>	<input type="checkbox"/>	<input type="checkbox"/>	<input type="checkbox"/>	<input type="checkbox"/>	<input type="checkbox"/>	<input type="checkbox"/>
Output register	<input type="checkbox"/>	<input type="checkbox"/>	<input type="checkbox"/>	<input type="checkbox"/>	<input type="checkbox"/>	<input type="checkbox"/>	<input type="checkbox"/>	<input type="checkbox"/>

Graphically, inputs, relays and outputs are always numbered from 0 to 7. First input, output, or relay (number 0) corresponds to the first Barix device input, output or relay.

For more information about the available number of inputs, outputs and relays, please refer to the “ABCL Firmware” technical documentation; it can be downloaded at www.barix.com.

6.2 DTMF/SIP INFO commands

After a dialog is successfully established, SIP Client application can accept commands sent by the remote party in the call. These commands can be transmitted either using DTMF tones, or by using the SIP INFO message.

NOTE 1: The remote SIP telephone/client must be configured to use either DTMF or SIP info for transmitting commands, but not both at the same time because this will result in decoding duplicated key presses on the Barix SIP client. For more details have to do that please refer to the documentation of the specific SIP phone/client;

NOTE 2: Every sequence must be entered with a maximum 5 seconds delay between every key, otherwise the sequence will be cleared, and the command must be entered from the start. The supported commands are listed in the table below:

Command	Description	Examples
NNNN	Web UI configured DTMF door open code.	1234 if the sequence match the preconfigured Web UI door open code, the relay is closed for the preconfigured time period.
#2*NNN*	Set relays state, NNN is the decimal value (0 to 255), representing an 8 bit bit-mask, to be applied.	#2*255* 255 mean binary “11111111” so the command set all relays to “1” (all closed). #2*2* 2 mean binary “00000010”

Command	Description	Examples
		so the command set relay "1" to 1(closed) and all other to 0 (open).
#3*NNN*	Set X8 outputs, NNN is the decimal value (0 to 255), representing an 8 bit bit-mask, to be applied.	See command "1".
#4*NNN*	Configure X8 contacts, NNN is the decimal value (0 to 255), representing an 8 bit bit-mask to set the behaviour of every X8 contact (1=output, 0=input).	#4*3* 3 mean "00000011", so X8 IO0 and IO1 are set as outputs, all the other contacts are set as inputs.
#5*N*	Enable/disable the audio rebroadcasting feature.	#5*0* disable audio rebroadcasting, #5*1* enable audio rebroadcasting,

Remarks:

1. If relay 1 is configured as the one to be switched on at call answer, and at the same time there is a door open code set, and the door code is typed in during the call, the relay will be switched off after the expire of the door lock timer. To prevent that, avoid using "Door Open" and "Enable relay on at call answer" at the same time. Another possibility is to configure the "Enable relay on at call answer" feature to use relay 2-8 when using Annunicom 1000;
2. When DTMF command is used to switch on any relay(s), only relay 1 is switched off automatically when the call is terminated. To close relays 2-8 a separate DTMF command needs to be sent.
3. When a X8 contact that is configured as input is tried to be set using DTMF command 3, the active call will be closed as it will be detected as a button press.
4. In order the status of X8 contacts to be correctly displayed after using DTMF command 4, the SIP client needs to be rebooted in order the X8 device to be properly reinitialised with the new settings

6.3 Control interface

A special control interface allow the remoter control of the device from the network, or from a serial cable connection.

A set of commands is supplied for this purpose. Command can be sent using one of the following method:

- through UDP packets
- through a TCP connection
- through a http cgi command, using the syntax:
http://IP_DEST/basic.cgi?command
- through a RS-232 command

The available commands are shown in the table below.

Command	Description	Examples
D[A][H][S]XXXX<CR>	Dial command, [H] means high priority, XXXXX is the SIP extension to call. [S] means stop active call. In this case all	DH1001<CR> the command will dial the 1001 extension, with an high priority [H] level.

Command	Description	Examples
	the rest characters (if any) from the command string are ignored [A] means “answer” the incoming call. In this case all the rest characters (if any) from the command string are ignored. If there is no incoming call, the command will be ignored.	DS<CR> will stop the active call. DA<CR> will answer the current incoming call
Q<CR>	Inquire device status, returns “UID,Sc,ii,oo,rr<CR>” with UID being the UserID (phone number), “c” - the connection state (0 = idle, 1 = calling, 2 = incoming call, 3 = connected, 4 = getting notification message), ii,oo,rr being respectively inputs , outputs and relays states as 2 digit hex numbers.	
Rnnn<CR>	Set relays state, nnn is the decimal value (0 to 255), representing an 8 bit bit-mask, to be applied. If the corresponding relay is not present on the device, its setting is ignored	R255 255 mean binary “11111111” so the command set all relays to “1” (all closed). R2 2 mean binary “00000010” so the command set relay “2” to 1(closed) and all other to 0 (open).
T[Q][Sxxxx]	Set/Query Input0 dial ID/target: TQ – returns the currently set Input0 call ID TSxxxx, where xxxx is a maximum 31 bytes call ID to be dialed at Input0 press	TS123456789 Will set the number to be dialed at button0/Input0 press to 123456789 TS123@192.168.1.201 Will set the call ID for P2P call to a device with ID=123 and IP=192.168.1.201
Xhhhh<CR>	Send data to serial port 1, as hex string (2 digits per byte). If this command is used from UDP, TCP, data received from the serial port will be streamed back as Xhhhhhh<CR> to the same interface. NOTE: no stream back for serial and CGI is available. This command work only if the selected serial port is not already used from accessories as X8, and if it is not issued from the SERIAL control channel. For more information refer to chapter Sending Data Using the X Command	X148454c4c4f<CR> Send an “HELLO” ascii string as hexadecimal values trough serial port 1.
XS	Stops the serial bridge, started by previous X command.	

6.4 Audio rebroadcast

This feature allows the audio redirection after a call has been established. When this feature is enabled, the same RTP received audio stream (uLaw or aLaw) will be forwarded to the remote target destination.

6.5 Background music

This feature allows to receive a UDP-RTP audio stream, as MPEG1 Layer 3 (MP3) or MPEG2 Layer 3, on a preconfigured port (see chapter [Advanced WEB UI Configuration](#)).

In the table below are listed the supported audio formats.

Supported BGM audio formats
MPEG2/22.05Khz
MPEG1/44.1Khz (MP3)
MPEG2/24Khz
MPEG1/48Khz (MP3)
MPEG2/16Khz
MPEG1/32KHz (MP3)

6.6 Notification Messaging

The SIP client can be configured to listen for RTP notification audio messages to a specific port. The notification audio can be sent via unicast, broadcast, or multicast. The following RTP payload types are supported and automatically detected from the RTP stream:

- PCM: 8,12,24,32,44.1 kHz MSB mono
- PCM: 8,12,24,32,44.1 kHz LSB mono
- PCM: 44.1, 48 kHz MSB/LSB stereo
- aLaw: 8,12,24,32 kHz mono
- uLaw: 8,12,24,32 kHz mono
- Mp3: The same types as for BGM

Two priority levels are available for the notification audio:

- **High priority** – In this case the notification message interrupts any pending or established SIP call. While the notification message is active, the SIP client will reject all incoming calls. After the end of the notification message the BGM playback is restored, and the SIP client can accept incoming calls.
- **Low priority** – In this case the SIP communication has a higher priority. The notification message will be received only in idle mode, or when playing BGM. While the notification message is active, any incoming SIP call will cancel it, and the SIP client will start ringing. After the end of the SIP call the device will switch back to the notification message if it is still active.

NOTE: The SIP client has a protection mechanism for ignoring notification audio streams with unsupported RTP packets. If such a stream is received, then the SIP client ignores the stream for the next 2 seconds to avoid performance issues and drops of the established SIP communication.

6.7 Using SIP Client with PS16

Starting from v.1.06 of the SIP Client, it is possible to use PS16 as a SIP telephone with 16 pre-configured destinations to call. Here is a brief tutorial how to use it:

Configuring PS16

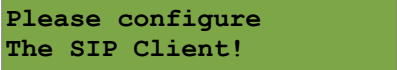
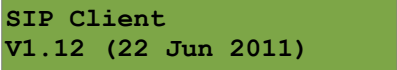
- Install the SIP ABCL FW using the HTTP update as described in chapter WEB UI ABCL SIP Firmware update. After rebooting the PS16, open the SIP client web page, and apply the factory defaults.
- On the first boot, you will see the following message in the display:

- Open the configuration page, and put the required SIP server, SIP ID (user name), and password from the Basic Settings page. The SIP profile should be already preset to "SIP Phone".
- Reboot the device. If the SIP client is successfully registered, you should see the idle message:

- Next you need to assign a call destination for all keys. Open the web interface, and go to **Configuration-->Advanced Settings-->Outbound Calls** configuration page. Configure all 8 call IDs from the **"Call on Device Inputs"** section to be used from PS16 buttons from 1 to 8 (the bottom row of keys). For the second row of keys please use the call IDs from the **"Call on X8 Inputs"** section.

Receiving Incoming Calls

When an incoming call is received, the PS16 will start ringing, and the LED on button 1 will start blinking. The Call ID of the calling party (if available) is also shown on the display. Press any key to answer the call, and any key to close the call.

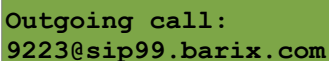
Making Outbound Calls

Press the corresponding target button to initiate the call. The PS16 shall start ringing, and the LEDs of this button will start blinking. A message will be shown on the display as well:



Press any key to cancel or close the call.

6.8 Using the serial interface

In order to be able to use the serial interface, it has to be enabled by choosing one of the following options:

- **"Serial Control Interface"**
- **"Serial GW, TCP, passive"**
-

If the **"X8 Extension"** option is selected, then the COM port is reserved for controlling the Barix X8 device, and cannot be used for anything else.

HOME	PROFILES	CONFIGURATION	STATUS	DEFAULTS
------	----------	---------------	--------	----------

SIP CLIENT

SIP Phone

Basic Settings	CONTROL INTERFACES	UDP Control Port	<input type="text" value="0"/>
Advanced Settings	TCP Control Port	<input type="text" value="12345"/>	
Network	Use Serial Port For	<input type="text" value="Serial Gateway, TCP, passive"/>	
SIP Protocol	Serial GW TCP port	<input type="text" value="13335"/>	
Outbound Calls	Serial Port 1 Settings	Baud Rate	<input type="text" value="115200"/>
Inbound Calls	Baud Rate	<input type="text" value="8"/>	
Audio	Data Bits	<input type="text" value="no"/>	
Control Interfaces	Parity	<input type="text" value="1"/>	
Streaming	Stop Bits	<input type="text" value="none"/>	
Security	Flow Control		

Illustration 12: Serial Port Settings page

If needed, the Serial Port 1 settings as could be modified for the purpose of your application. Click **“Apply”** and reboot the device in order the new setting to take effect.

Command Mode

To enable it, select **“Serial Control Interface”**. In command mode the serial interface can be used to send commands as you can do via the UDP, TCP, or CGI interfaces as described at the beginning of this section. The following rules imply:

- The X command cannot be initiated via the serial interface;
- The commands should be terminated by <CR>, so take care to configure your terminal or application to terminate them with <CR>, and not with <CR><LF>;
- The sent commands are echoed locally;

Sending Data Using the X Command

When the X command is used from the TCP/UDP port, or from the CGI interface, the serial port enters in a data transmission mode. In this case, the serial port starts receiving the data, sent by the initiating interface, and sends data back to it. The following rules imply in this case:

- The reverse channel (sending data from the serial interface back to the interface that has issued the X command) works only with TCP and UDP interfaces. There is no stream back (reverse channel) when the X command is sent via the CGI interface;
- The data being sent from the UDP/TCP/CGI interface must be preceded by X, like:

```
X12345678
```

- The serial interface adds the “X” to the data that are being sent back to the UDP/TCP interface, so for example if we send the sting “hello” from the

serial interface, we will get the following on the TCP interface:

X68656C6C6F

Let's illustrate this with a specific example. For this purpose we will use a SIP client with Control Interfaces settings as shown above, and a Serial Terminal Emulator. You can use any terminal out of the following non-exhaustive list:

Serial Terminal	Windows	Linux	MacOS
Hyperterminal	X	-	-
TeraTerm	X	-	-
CoolTerm	-	-	X
ZTerm	-	-	X
GTKTerm	-	X	-
Cutecom	-	X	X

In our example we will use the CoolTERM terminal emulator application for MacOS

First, configure your SIP client as requested, and reboot the device.

Second, run the CoolTERM and click on **Connection** → **Options** menu item. The configuration panel will appear:

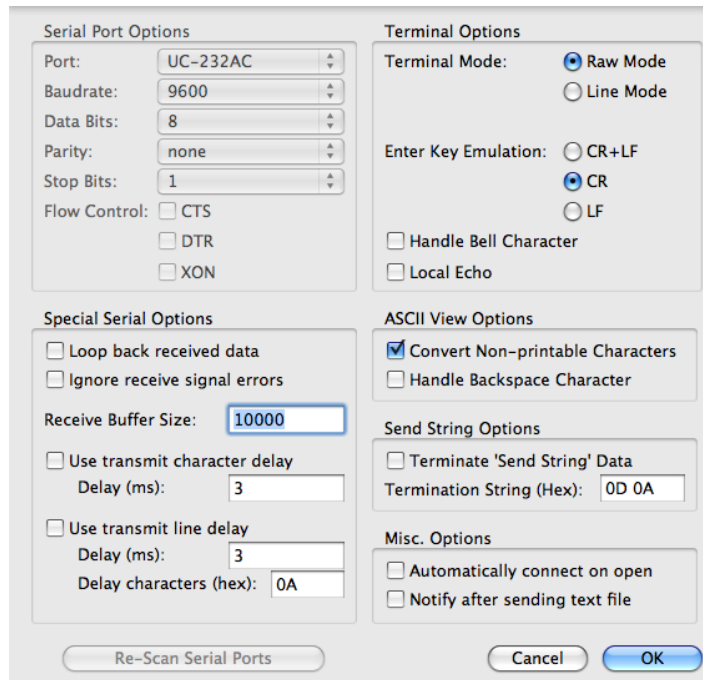

Illustration 13: Serial Terminal CoolTerm settings

Check your serial port options, and make sure you select <CR> for the Enter key emulation. Click OK, then click the **“Connect”** button to connect the terminal to the configured COM port.

Next, open bash prompt, and run telnet:

```
my-imac24-2:~ myuser$ telnet 192.168.3.181 12333
Trying 192.168.3.181...
Will map carriage return on output.
Will send carriage returns as telnet <CR><LF>.
Connected to C00FCDD0.barix.local.
Escape character is '^]'.
X12345678
X999988888
X68656C6C6F
X68656C6C6F0D
XS
^]
telnet> quit
Connection closed.
my-imac24-2:~ myuser$
```

Type the first two commands (X12345678 and X999988888). The data should be displayed on the CoolTERM window:

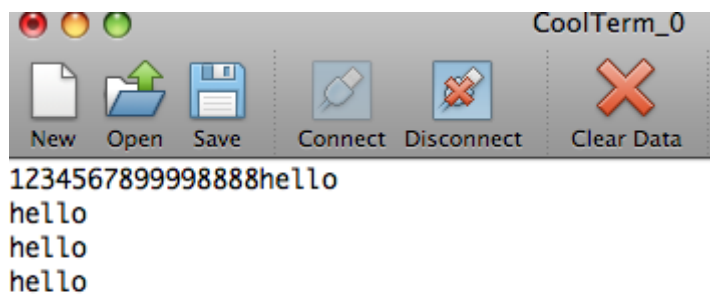

Next, click on **Connection** → **Send String** from the menu bar, and type “hello” in the window.

Click **“Send”**:

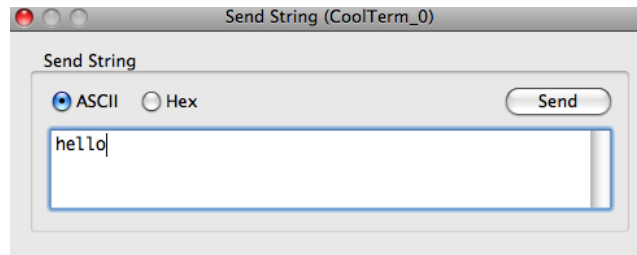

The data should be displayed in the telnet window as X68656C6C6F. Mind the starting **“X”** added by the serial interface at the beginning. Now, do the same, but adding a <CR> at the end by pressing **“Enter”**:

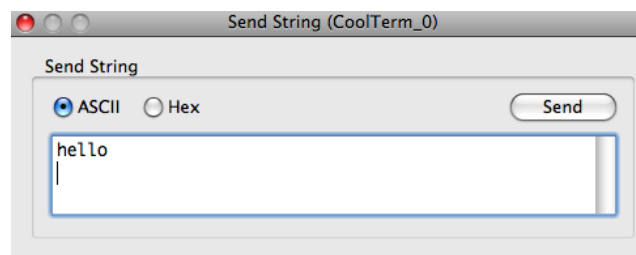

The displayed data now should look like: X68656C6C6F0D

Now, type **XS** from the telnet window to disable the serial gateway. Click **“Send”** several times- now you should see the string echoed on the CoolTerm window instead of being sent to the remote end.

Last, press **Ctrl-J** and type **quit** to close the telnet session.

Transparent Serial-to-TCP passive gateway

This feature allows to transparently transfer data in full-duplex mode between the Serial COM port of the SIP client, and a TCP connected remote host without the need to use the X command.

To enable it, select **“Serial GW, TCP, passive”** from the **“Use Serial Port For”** drop-down menu. The remote host must open a TCP connection to the SIP client in order the gateway to be functional. The TCP port to which the SIP client will listen for incoming TCP connections is configured via the webUI as shown on Illustration 12.

Setting up the tunnel is quite similar to the case when sending data using the X command:

First, open the serial terminal emulator, and configure it as specified above. Make sure you select the correct serial port device, and configure the same COM port settings as configured in the SIP client COM port settings, and click **Connect** to open the COM port device.

Next, open bash prompt, and run telnet:

```
my-imac24-2:~ myuser$ telnet 192.168.3.181 13335
Trying 192.168.3.181...
Will map carriage return on output.
Will send carriage returns as telnet <CR><LF>.
Connected to C00FCD0.barix.local.
Escape character is '^]'.
test
===== start of test file =====
89:;<=>?@ABCDEFGHIJKLMNORSTUVWXYZ[\]^_`abcdefghijklmnopqrstuvmxyz{|}~
```

```

9:;<=>?@ABCDEFGHIJKLMNOPQRSTUVWXYZ[\]^_`abcdefghijklmnopqrstuvwxyz{|}~ !
:;<=>?@ABCDEFGHIJKLMNOPQRSTUVWXYZ[\]^_`abcdefghijklmnopqrstuvwxyz{|}~ !"
;<=>?@ABCDEFGHIJKLMNOPQRSTUVWXYZ[\]^_`abcdefghijklmnopqrstuvwxyz{|}~ !"#
<=>?@ABCDEFGHIJKLMNOPQRSTUVWXYZ[\]^_`abcdefghijklmnopqrstuvwxyz{|}~ !"#$
.....
6789:;<=>?@ABCDEFGHIJKLMNOPQRSTUVWXYZ[\]^_`abcdefghijklmnopqrstuvwxyz{|}
789:;<=>?@ABCDEFGHIJKLMNOPQRSTUVWXYZ[\]^_`abcdefghijklmnopqrstuvwxyz{|}~
89:;<=>?@ABCDEFGHIJKLMNOPQRSTUVWXYZ[\]^_`abcdefghijklmnopqrstuvwxyz{|}~
===== end of test file =====
^]
telnet> quit
Connection closed.
my-imac24-2:~ myuser$

```

Type the “test” - it should appear in the CoolTerm terminal window. Next, click on **Connection-->Send Text File**, and select an plain ASCII file to send. The data should start appearing in the telnet window.

When finished, press **Ctrl+]** and type “quit” to close the telnet session. With this, the established Serial-to-TCP tunnel is destroyed.

6.9 Configuring and connecting X8

If triggering of calls to more than 2 targets is desired, then BARIX X8 device must be correctly configured and connected to COM port of the device.

X8 pinout

The pinout of the X8 device is shown on the picture below:

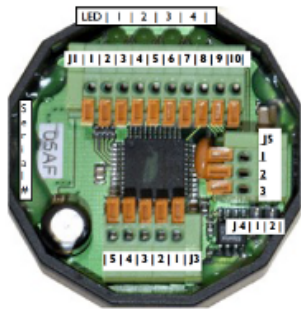

J1		J3	
Pin	Purpose	Pin	Purpose
1	Signal GND	1	Reference GND
2	I/O 7	2	RS-485A
3	I/O 6	3	RS-485B
4	I/O 5	4	Vin (AC or DC)
5	I/O 4	5	Vin (AC or DC)
6	I/O 3	J5	
7	I/O 2		
8	I/O 1	1	Shield
9	I/O 0	2	Shield
10	Vcc (5V DC)	3	Shield

Programming X8

The X8 device provided by Barix must be configured for a special mode in order to be used for the needs of SIP application. In general, this is the default mode of X8, but if you have changed it for some reason, or if not sure in what mode the X8 is programmed, then follow the procedure below to reset to the default parameters:

- Connect inputs I0 and I1 together (pins 9 and 8 of J1) as shown on the

picture:

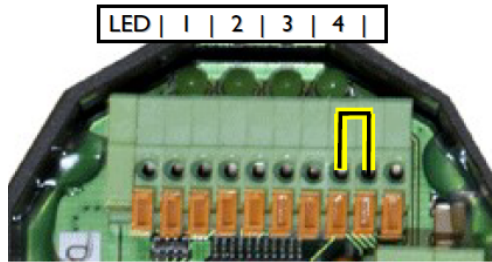

- Power up X8. The device will reset to factory defaults. All LEDs will be illuminated, LED 3 will blink showing that the default parameters have been stored in the non volatile memory.
- Remove the power, then remove the bridge between pins 8 and 9. The X8 is now ready for use.

After connecting the X8 to the device the left LED1 will blink every second, while LED2 and LED3 will randomly blink showing the exchange of Modbus data and commands between X8 and the SIIP client. The X8 can be accessed on Modbus address 255 using the following serial settings: 19200,8 bits, No parity, No handshake.

Configuring the COM port for X8

In order the X8 to function properly, open the application **Advanced Settings -> Control interfaces** page, and set **“Use Serial Port for”** to **“X8 extension”**. In this application is automatically reconfigured to to use the correct COM port settings depending on the used device (Annunicom 100/200 or Annunicom 155). In this case the Serial 1 COM port settings are ignored, even if it is possible to change them from the configuration page.

Connecting the X8 to Annunicom 100/200

Next, you need to connect the X8 to the device. To connect it to COM1 PORT of Annunicom 100/200, you need to prepare an adapter cable using the connection diagram below.

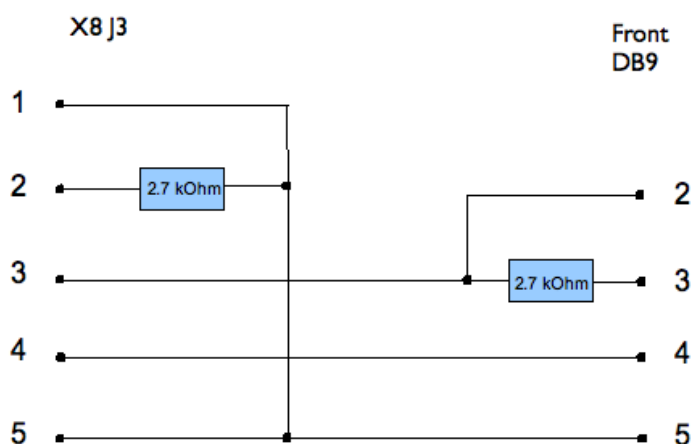

Connecting the X8 to Annunicom 155

Connecting the X8 to Annunicom 155 is easier, because in this case the RS232 to RS485 adapter cable is not needed. Connect the X8 directly to the COM2 port of Annunicom 155 using the following connection diagram:

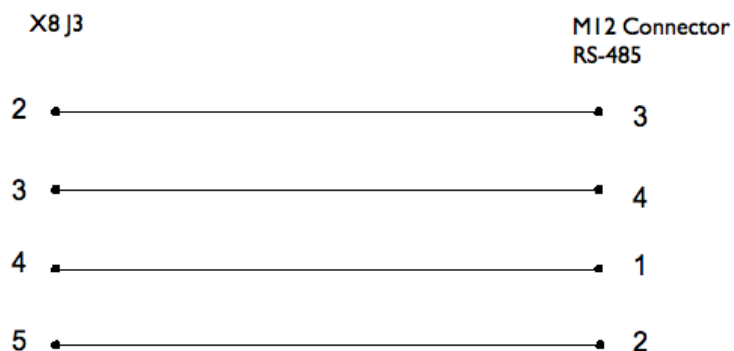

For more Information about the pinout of the M12 connector on the Annunicom 155 front panel, please refer to the supplied documentation, or download the [Annunicom 155 Product Manual](#) from the BARIX website.

Connecting buttons to the X8 Unit

For the purpose of this application, the most simple configuration is used. Connect your buttons or contact closures between each input and signal ground as shown in the picture below.

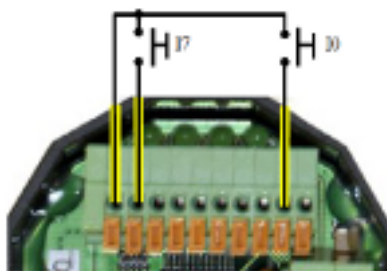

However, up to 70 buttons and a volume control may be connected if desired. The application also needs to be modified to support more buttons. For more information please refer to BARIX customer support.

6.10 Using the Backup SIP server feature

In v2.16 of the SIP client Barix has introduced the possibility to configure a backup SIP server feature. When the device fails to register to the main SIP server due to timeout (i.e. server is not reachable or available at the moment) or when the server replies with **“Error 503: Service unavailable”** message, the SIP client will try to register to the backup server.

The operation logic of the **“Backup SIP server”** feature is as follows:

1. At boot, the SIP client will check the two SIP server entries, and try to resolve them. If the DNS resolution was successful, it will remember the resolved IP addresses for use.
2. The SIP client tries to register periodically with at a predefined period set by the SIP server during the last successful registration. If the first REGISTER message fails, the SIP server keeps on retrying the last REGISTER message every 3 seconds until the timeout configured by the **“Registration Fail Timeout”** setting expires. At this moment, if the registration is still failing, the SIP client will switch to the backup SIP server, and try to register with it using the **same** SIP ID and password.
3. If both servers are not reachable, the SIP client will try them again the next registration period.
- 4.

NOTE: Please have in mind that enabling this feature will disable the use of the **“Periodically Renew DNS”** feature even if it is configured.

7 Common issues

7.1 SIP server compatibility

Early SDP Offer vs. Late SDP Offer

Barix SIP client implementation is using "Early SDP offer" (i.e. SDP in the INVITE SIP message) which is the culprit when used with PBX server which is configured to use "Late SDP offer" (i.e. SDP in the ACK SIP message) as default (e.g. Mitel, Cisco CUCM), which results in missing audio when the call is established. In this case the PBX must be configured to use "Early SDP offer" (e.g. called "[Early Media](#)" in Cisco CUCM).

Authentication ID

Some SIP PBX require Authentication ID (sometimes also called Authorisation user name) which is different than the SIP ID/Username (which is usually the SIP extension number). For SIP client prior to v2.14 it was necessary to configure the same ID as Authentication ID and SIP ID(Username). Starting from SIP v2.14 you can configure Authentication ID separately.

SIP Proxies and Virtual IP configurations

SIP proxies and Virtual IP configuration (e.x. used by Shoretel) are not supported.

7.2 SIP REGISTER fail

- Check that the server is reachable, for example using the "ping" command from the command prompt. A reply, as shown below, must be received.

```
john@barix:~$ ping 192.168.0.20
PING 192.168.0.20 (192.168.0.20) 56(84) bytes of data.
64 bytes from 192.168.0.20: icmp_seq=1 ttl=64 time=16.1 ms
64 bytes from 192.168.0.20: icmp_seq=2 ttl=64 time=14.9 ms
64 bytes from 192.168.0.20: icmp_seq=3 ttl=64 time=12.9 ms
```

- If no reply is received, check the network connections and the server configuration.
- Check device WEB UI "SIP Id" and "SIP Password" fields to be correct.
- Check the Syslog messages sent from the device. An error message 401 (Unauthorised) means a bad "SIP Id" or "SIP Password".

7.3 Remote peer don't receive any audio after call established

- Check the WEB UI "Input Source" field to be correct.
- Check the WEB UI "A/D Amplifier Gain" and "Microphone Gain" fields.

7.4 Nothing audible after call established

- Check the WEB UI "Volume" field.

7.5 Internet dialog, audio missing after call established

When a call is established with a peer located outside of the local network, through a router, add a redirection rule on your local LAN gateway setup. For example, if the Barix device RTP audio port is 5004 (default) and the device LAN IP is 192.168.0.2, a rule must be added as described below.

UDP 5004 --- redirect to → UDP 192.168.0.2 : 5004

Please see the specific router/gateway manual, looking for a “Port Redirection” or “Port Forwarding” section.

7.6 Internet dialog, call terminate early

Try to enable the “Send NAT-Keepalives” option. If this doesn't solve the issue, please refer to the server side PBX log debug traces.

7.7 Background music does not start

If the device is correctly configured to play BGM while in idle mode, and the BGM does not start when the device boots, please check that you have both SIP server and SIP user ID set in sip server mode, or the SIP ID only in P2P mode.

If these values are not set the application will exit after boot, and not do anything.

7.8 DTMF command not executed, or the door relay is not opened

Check if the remote SIP telephone has both SIP INFO and DTMF enabled at the same time. If yes—configure it to use only one of these methods. Here is an example how to do it on SNOM 360:

Open the web configuration page, and go to your Identity-->SIP page. Find the option „DTMF via SIP info“, and set it to „Off“:

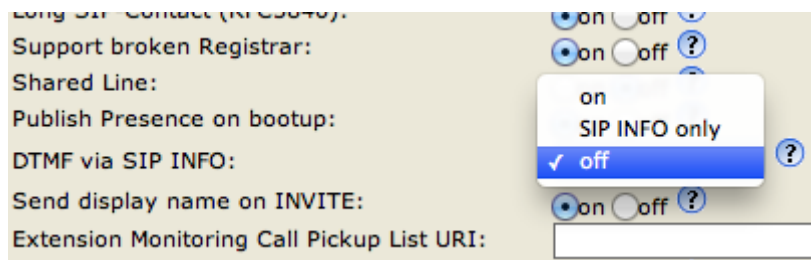

8 Additional Information

8.1 WEB UI “ABCL SIP” firmware update

From the main WEB menu, click on the “Update” button. You will see the update page. Click on “Browse”, then navigate to the update_rescue/compound.bin in the directory where you have unzipped the abcl_sip_vXX.XX_DATE.zip file. Select it, then click on the “Upload” button to continue.

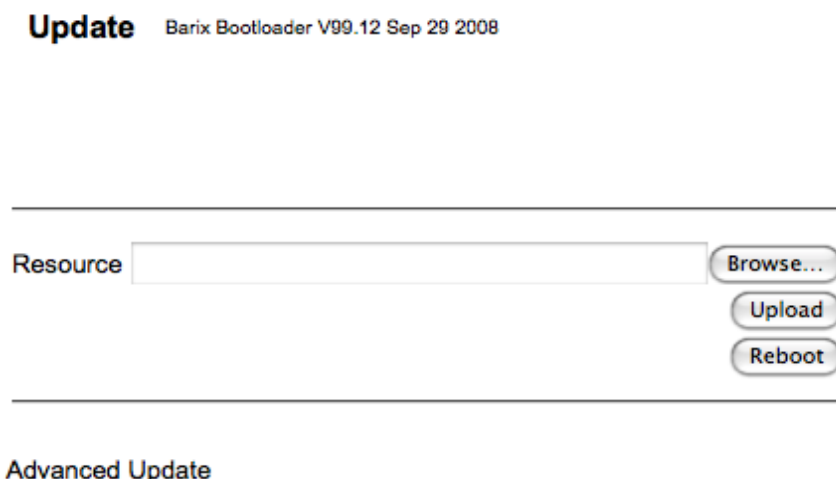

Illustration 14: Device upload web page

Reboot the device when the update is finished, and open the web UI at the announced IP address. Navigate to the reboot page by clicking on the “Reboot” tab, then select “SIP Client (sip)” from the Application drop-down menu, and click the “Apply” button. The device will reboot again.

8.2 Updating a device using the RS-232 serial port

Sometimes when the device is not accessible via the LAN, or the image in the flash memory is corrupted for some reason, then a serial rescue may be needed to reset the device to the factory defaults².

So, here are the steps that need to be executed to do the serial rescue:

- Disconnect the device from the power supply;
- Connect the COM port of the device to the COM port of your computer via a null modem serial cable;
- Open a terminal in the update_rescue directory in your unzipped copy of the ABCL SIP firmware. If using Linux or Mac, switch to update_rescue/linux or update_rescue/mac directory;

² Rescuing the SIP Client using the serial port is more complex, and requires some engineering work. Please contact BARIX Support to get more information.

- Start the rescue process by executing ipamresX, where X is the number (1-4) of the serial port on the computer;
- If running on Linux /Mac execute the ipamresd.sh script, giving the device name of your COM port as a parameter. For ex.:

```
./seriald.sh /dev/tty.UC-232AC
```

- Power on the device, and wait for the update to finish. The device will reboot automatically.

NOTE: All other settings except the network settings will be lost !

8.3 BIN / DEC / HEX conversion

Hexadecimal digits have values from **0..15**, represented as **0..9** and as **A** (for 10) to **F** (for 15).

The following table can serve as a conversion chart:

Bin /DEC / Hex Table

Decimal	Binary	Hexadecimal
0	0000	0
1	0001	1
2	0010	2
3	0011	3
4	0100	4
5	0101	5
6	0110	6
7	0111	7
8	1000	8
9	1001	9
10	1010	A
11	1011	B
12	1100	C
13	1101	D
14	1110	E
15	1111	F

To convert a binary value in a hexadecimal representation, the upper and lower four bits are treated separately, resulting in a two-digit hexadecimal number.

9 Dictionary

Class A network

- IP address **1.x.x.x** to **127.x.x.x**

Only 127 different networks of this class exist. These have a very large number of potential connected devices (up to 16'777'216).

- Example: **10.0.0.1** (network **10**, host **0.0.1**)

Class B network

- IP address **128.0.x.x** to **191.255.x.x**

These networks are used for large company networks. Every network can consist of up to 65534 devices.

- Example: **172.1.3.2** (network **172.1**, host **3.2**)

Class C network

- IP address **192.0.0.x** to **223.255.255.x**

Class C networks are most common and for smaller companies. These networks can consist of a maximum number of 254 hosts.

- Example: **192.7.1.9** (network **192.7.1**, host **9**)

Class D network

The remaining addresses **224.x.x.x** - **239.x.x.x** are defined as "Class D" and are used as multicast addresses.

Class E network

No addresses are allowed with the four highest order bits set to "1" (**240.x.x.x** - **254.x.x.x**).

These addresses, called "class E", are reserved.

DHCP

Short for Dynamic Host Configuration Protocol, a protocol used to assign an IP address to a device connected to a Network.

FDX

Short for Full Duplex. A full-duplex system allows communication between two parties to be done in both directions simultaneously. See [this](#) Wikipedia article for more information.

HDX

Short for Half Duplex. In a half-duplex system simultaneous communication in both directions is not possible, i.e. if one of the parties is sending, the other have to wait it to finish before

replying. See [this](#) Wikipedia article for more information.

IP

Short for Internet Protocol, the IP is an address of a computer or other network device on a network using IP or TCP/IP. Every device on an IP-based network requires an IP address to identify its location or address on the network. Example: **192.168.2.10**

Ipzator

Barix IPzator™ technology is designed for the purpose that the Barix device can create its own IP address according to the network structure in case it can't receive one from your network. If DHCP, AUTOIP or BOOTP fail, IPzator will create an IP address within the subnet and test it (starting with **x.x.x.168** and if occupied incrementing by one). If the address works and is not being used by another device on the network, it will give the address to the Barix device.

IP Addressing

An IP address is a 32 bit value, divided into four octets of eight bits each. The standard representation is four decimal numbers (in the range of 0..255), divided by dots.

- Example: **192.2.1.123**

This is called decimal-dot notation. The IP address is divided in two parts: a network and a host part. To support different needs, five "network classes" have been defined. Depending on the network class, the last one, two or last three bytes define the host, while the remaining part defines the network. In the following text, 'x' stands for the host part of the IP address.

- Example: **192.168.0.x**

IP Netmask

The Netmask is used to divide the IP address differently from the standard defined by the classes A,B and C.

Entering a Netmask, it is possible to define how many bits from the IP address are to be taken as the network part and how many bits are to be taken as the host part.

Standard IP network Netmask:

Class	Network bits	Host bits	Netmask
A	8	24	255.0.0.0
B	16	16	255.255.0.0
C	24	8	255.255.255.0

Netmask examples:

Netmask	Host bits
255.255.255.252	2
255.255.255.248	3
255.255.255.240	4
255.255.255.224	5
255.255.255.192	6
255.255.255.128	7

255.255.255.0	8
255.255.254.0	9
255.255.252.0	10
255.255.248.0	11
.	.
.	.
255.128.0.0	23
255.0.0.0	24

MAC address

Abbreviation for Medium Access Control, a MAC is a unique address number formatted in hexadecimal format and given to each computer and/or network device on a computer network. Because a MAC address is a unique address a computer network will not have the same MAC address assigned to more than one computer or network device.

Example:**A1:B2:C3:D4:E5:F6**

Netmask

A number used to identify a sub network so that an IP address can be shared on a LAN (Local Area Network).

A mask is used to determine what subnet an IP address belongs to. An IP address has two components, the network address and the host address. For example, consider the IP address **150.215.017.009**. Assuming this is part of a Class B network, the first two numbers (**150.2**) represent the Class B network address, and the second two numbers (**.017.009**) identify a particular host on this network.

The Netmask would then be **255.255.0.0** .

Network Address

The host address with all host bits set to "0" is used to address the network as a whole (for example in routing entries).

- Example: **192.168.0.0**

Network addresses can not be used as a host address!

Private IP Networks and the Internet

If your network is not connected to the Internet and there are no plans to make such a connection you may use any IP address you wish.

However if you are not connected to the Internet and have plans to connect to the Internet or you are connected to the Internet and want to operate your Barix device on an intranet you should use one of the sub-networks below for your network. These network numbers have been reserved for such networks. If you have any questions about IP assignment ask your Network Administrator.

Private IP networks by class:

Class	Network
A	10.x.x.x
B	172.16.x.x
C	192.168.0.x

Network RFC's

For more information regarding IP addressing see the following documents. They can be found on the Internet:

RFC	Description
950	Internet Standard Subnetting Procedure
1700	Assigned Numbers
1117	Internet Numbers
1597	Address Allocation for Private Internets

SIP

The Session Initiation Protocol (SIP) is a signalling protocol, widely used for controlling multimedia communication sessions such as voice and video calls over Internet Protocol (IP). The protocol can be used for creating, modifying and terminating two-party (unicast) or multiparty (multicast) sessions consisting of one or several media streams. The modification can involve changing addresses or ports, inviting more participants, adding or deleting media streams, etc. Other feasible application examples include video conferencing, streaming multimedia distribution, instant messaging, presence information and online games.

SIP Dialog

A dialog is a peer-to-peer SIP relationship between two user agents that persists for some time.

SIP Message

Message: Data sent between SIP elements as part of the protocol.
SIP messages are either requests or responses.

SIP Registrar

A registrar is a server that accepts REGISTER requests and places the information it receives in those requests into the location service for the domain it handles.

Static IP

A Static IP is a fixed IP address that you assign manually to a device on the network. It remains valid until you disable it.

UAC

SIP terminology, means "user agent client", to indicate generally the device that start a transaction, sending a request to a server (UAS).

UAS

SIP terminology, means "user agent server", to indicate generally the device that start a transaction, receiving a request from a client (UAC).

Illustration Index

Illustration 1: SIP Client use cases.....	9
Illustration 2: Connecting Annunicom 100.....	12
Illustration 3: Home page of unconfigured SIP client.....	13
Illustration 4: SIP client Basic Settings menu page.....	14
Illustration 5: Home page of a configured and registered SIP client.....	15
Illustration 6: SIP Client Profiles page.....	19
Illustration 7: SIP Client Configuration page.....	21
Illustration 8: Device status page.....	31
Illustration 9: SIP application status page.....	32
Illustration 10: SIP Client EEPROM settings status page.....	32
Illustration 11: Factory Defaults page.....	33
Illustration 12: Serial Port Settings page.....	42
Illustration 13: Serial Terminal CoolTerm settings.....	44
Illustration 14: Device upload web page.....	51

10 Legal Information

© 2012 Barix AG, Zurich, Switzerland.

All rights reserved.

All information is subject to change without notice.

All mentioned trademarks belong to their respective owners and are used for reference only. Barix and SIP Client are trademarks of Barix AG, Switzerland and are registered in certain countries.

For information about our devices and the latest version of this manual please visit www.barix.com.

Barix AG
Seefeldstrasse 303
8008 Zürich
SWITZERLAND

T +41 43 433 22 11
F +41 44 274 28 49

www.barix.com
sales@barix.com
support@barix.com